

LILY

FINISHED QUILT TOP: 78" X 80"
FINISHED BLOCKS: 15" SQUARE

*Made sometime between 1930-40,
Lily's appliqué sweetness lives on.*

MATERIALS

- 4-6 fat quarters assorted green solids for lilies and stems (*fat quarter = 18" x 22"*)
- 4-6 fat quarters assorted pink prints for lilies and center squares (*fat quarter = 18" x 22"*)
- 3¼ yards white solid
- 2½ yards green solid for sashing and borders
- 9 assorted 4½" squares for cornerstones
- ⅔ yard stripe for binding
- 7½ yards backing fabric
- 86" x 88" rectangle of batting
- Template plastic



Quiltfolk

FOUNDRY



Quiltfolk

FOUNDRY

LILY

/// QUILT NO. 010

LILY

FINISHED QUILT TOP: 78" X 80"
FINISHED BLOCKS: 15" SQUARE

We fell for an appliqué quilt created in springtime pastels. Create your own version of Lily with any color in the garden.

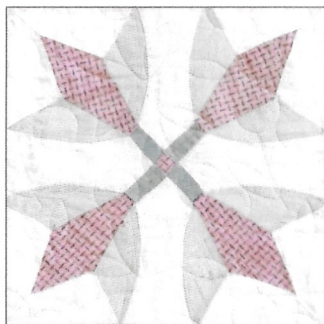

MATERIALS

- 4–6 fat quarters assorted green solids for lilies and stems (*fat quarter = 18" x 22"*)
- 4–6 fat quarters assorted pink prints for lilies and center squares (*fat quarter = 18" x 22"*)
- 3¼ yards white solid
- 2½ yards green solid for sashing and borders
- 9 assorted 4½" squares for cornerstones
- ⅔ yard stripe for binding
- 7½ yards backing fabric
- 86" x 88" rectangle of batting
- Template plastic

CUTTING

Measurements include ¼" seam allowances.

- Trace patterns A, B, C, and D on template plastic and cut them out.
- Trace a second set of templates **without** the seam allowances. (These will be used to mark seam allowances on fabric pieces.) To cut mirror-image B and C pieces, flip the templates over and trace around them on the fabric.

FROM ASSORTED GREEN SOLIDS, CUT:

- (16) matching sets of 4 Bs, 4 mirror-image Bs, and (4) 1⅜" x 2⅞" rectangles.

FROM ASSORTED PINK PRINTS, CUT:

- (16) sets of 4 matching As and (1) 1⅜" square.

FROM WHITE SOLID, CUT:

- (64) Ds.
- (64) Cs and (64) mirror-image Cs.

FROM GREEN SOLID, CUT:

- (16) 4½" x WOF strips. From 12 strips, cut (24) 4½" x 15½" sashing rectangles.
- (4) 3½" x WOF strips.

FROM STRIPE FABRIC, CUT:

- (9) 2¼" x WOF strips.

PATTERN INSTRUCTIONS

PREPARATION

Center the templates without seam allowances on the wrong side of the A, B, C, and D fabric pieces. Trace around the templates with a fine point marker, such as a mechanical pencil, to mark seamlines for hand piecing.

Block Assembly

These instructions are written for fabrics to match within the blocks. You might choose to mix them up the way the quiltmaker did. Refer to the quilt photo for inspiration.

1. Sew a green B and a mirror-image green B to a pink print A to make a Lily unit as shown. Make 4 matching Lily units.

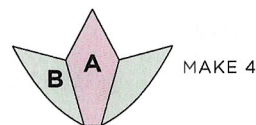

2. Sew a white C and a mirror-image C to a Lily unit. Stitch center seam between the Cs to complete a Corner unit. Make 4.

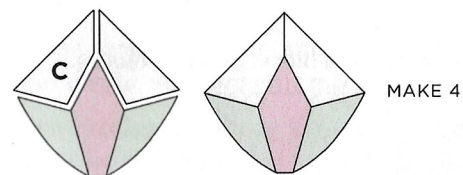

3. Sew a white D between 2 Corner units to make a Lily unit.

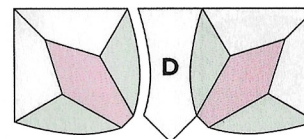



4. Sew a $1\frac{3}{8}$ " x $2\frac{1}{4}$ " green rectangle to the left side of one white D as shown. Join a $1\frac{3}{8}$ " pink square to a $1\frac{3}{8}$ " x $2\frac{1}{4}$ " green rectangle, and then sew the pieced unit to the right side.



5. Join the D unit and 2 Corner units.

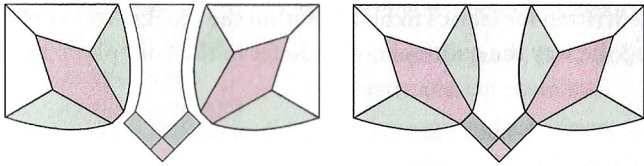

6. Sew 2 white Cs to the Lily unit to complete the bottom section.

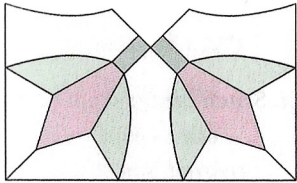

7. Join the top and bottom sections to complete a block. Make 16 blocks.

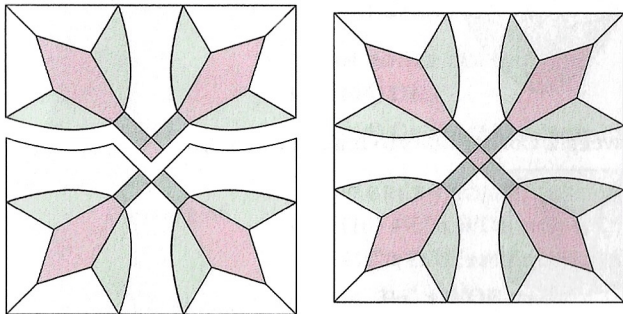

Quilt Assembly

1. Lay out the blocks, $4\frac{1}{2}$ " x $15\frac{1}{2}$ " green sashing rectangles, and $4\frac{1}{2}$ " print squares in rows as shown in the *Quilt Assembly Diagram*.
2. Sew the blocks, sashing rectangles, and squares into rows and then join the rows.
3. Join the $3\frac{1}{2}$ " x WOF green strips end to end. Measure the length of the quilt and cut 2 borders equal to that measurement from the piece strip. Sew the borders to the sides of the quilt.
4. Join the $4\frac{1}{2}$ " x WOF green strips end to end. Measure the width of the quilt, including borders, and cut 2 borders equal to that measurement from the pieced strip. Sew the borders to the top and bottom of the quilt.

Finishing

1. Cut backing fabric into (3) $2\frac{1}{2}$ -yard lengths. Cut a 10"-wide lengthwise piece from one of the $2\frac{1}{2}$ -yard pieces, and sew it between the remaining $2\frac{1}{2}$ -yard pieces. The wider piece is extra.
2. Layer backing, batting, and quilt top. Baste for hand quilting or pin baste for quilting on your domestic machine.
3. Sew binding strips together end to end with diagonal seams. Press strip in half lengthwise. Add binding to the quilt using your favorite method.

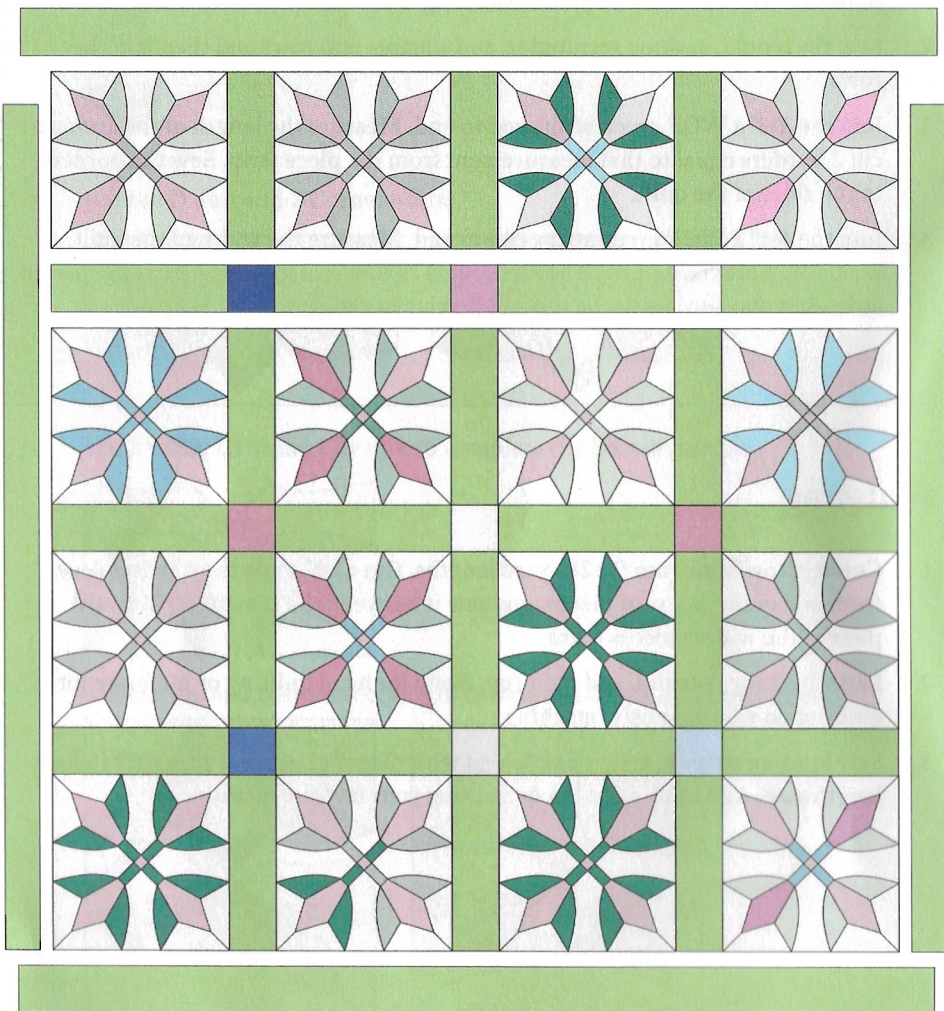

Quiltfolk



FOUNDRY

*“Tell the stories
behind the stitches.”*

Since 2016, this simple idea has been the heartbeat of Quiltfolk. And the establishment of the Quiltfolk Foundry in 2022 has allowed us the opportunity to continue telling the stories of quilts that have gotten lost along the way.

The Quiltfolk Foundry is where lost quilt tops and blocks are found, then finished by a trusted circle of talented home sewists and quilters who turn the lost materials into beautiful quilts offered for sale in our shop.

We hope you enjoy our line of patterns, inspired by Foundry quilts that are ready for the next chapter in their story.

#QUILTFOLKPATTERNS

Join our community

Follow @Quiltfolk for inspiration, and share your own projects to inspire others! Use the hashtag #QuiltfolkPatterns so that we can see and share what you make.



Quiltfolk FOUNDRY

LILY | QUILT NO. 010

Templates

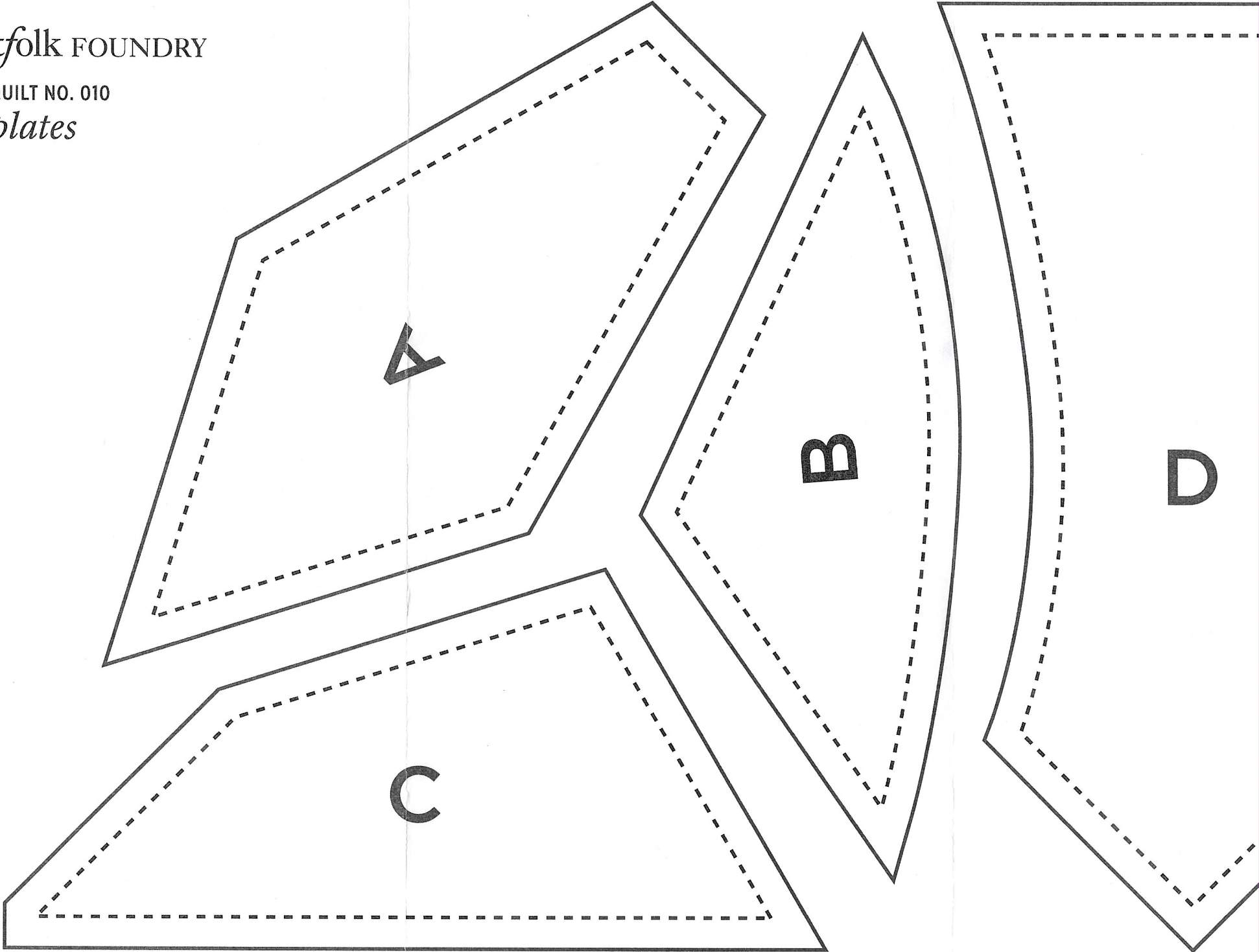

UNDY

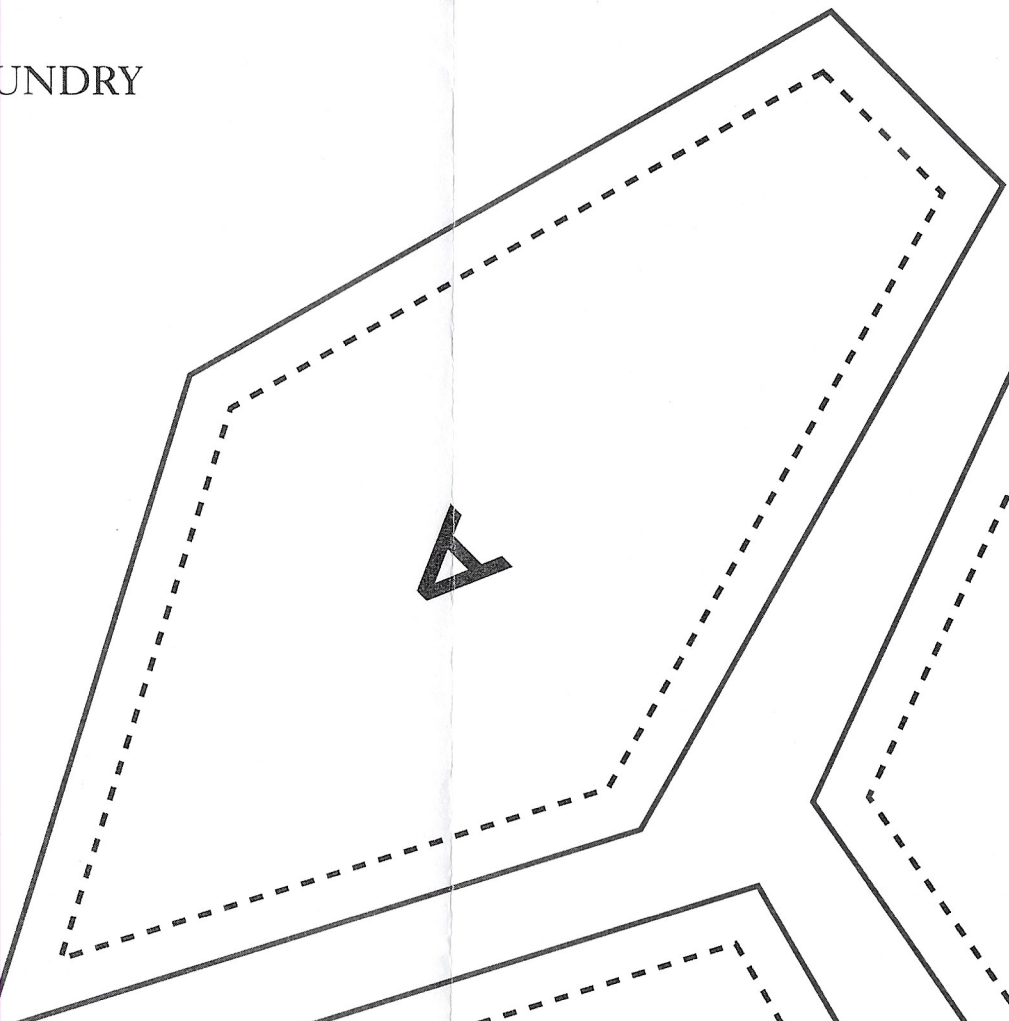

A

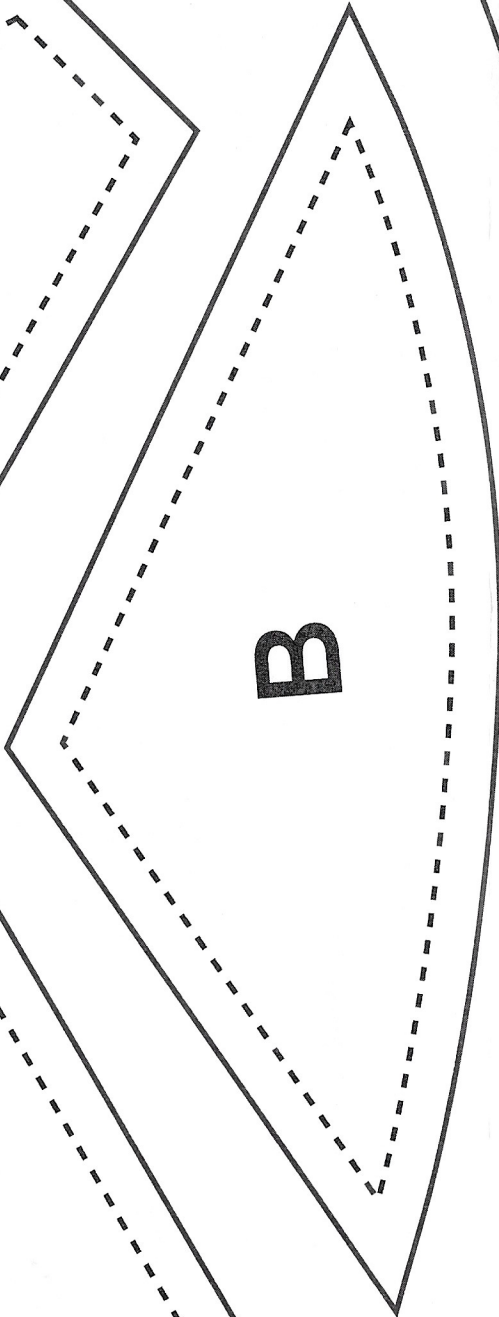

B

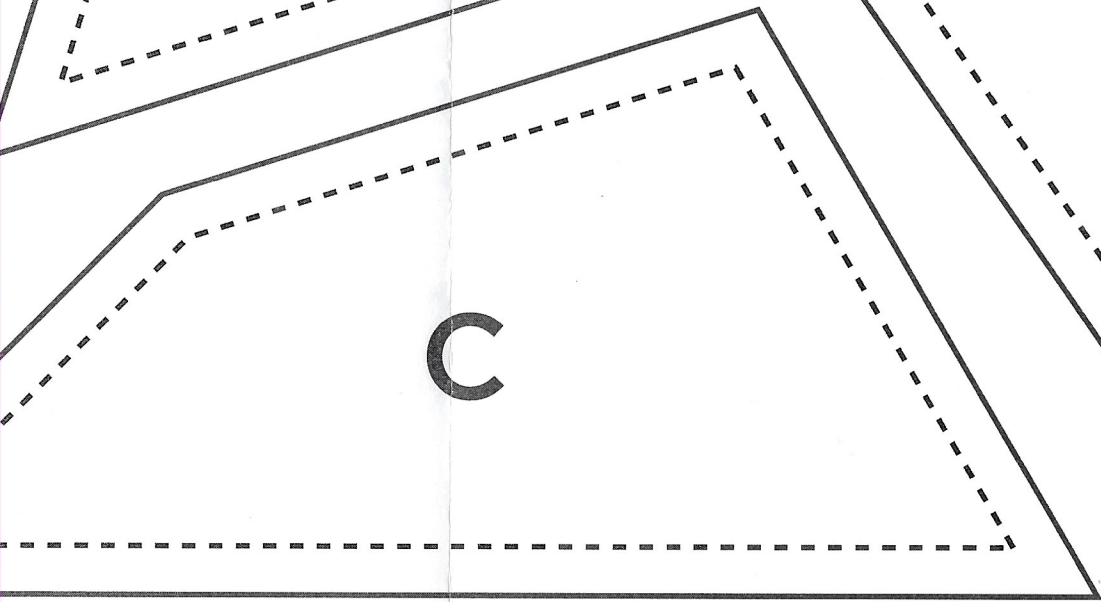

C

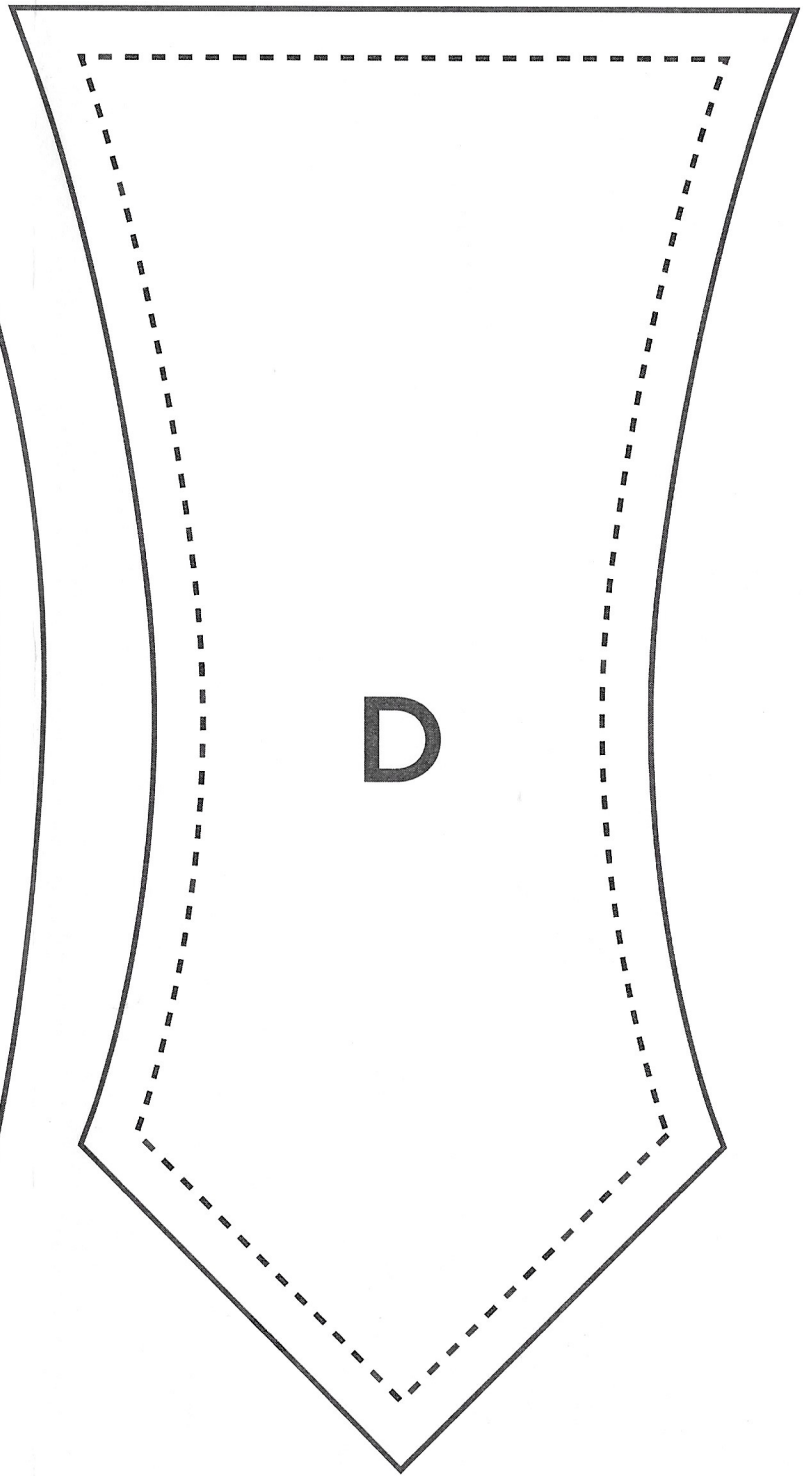

D